

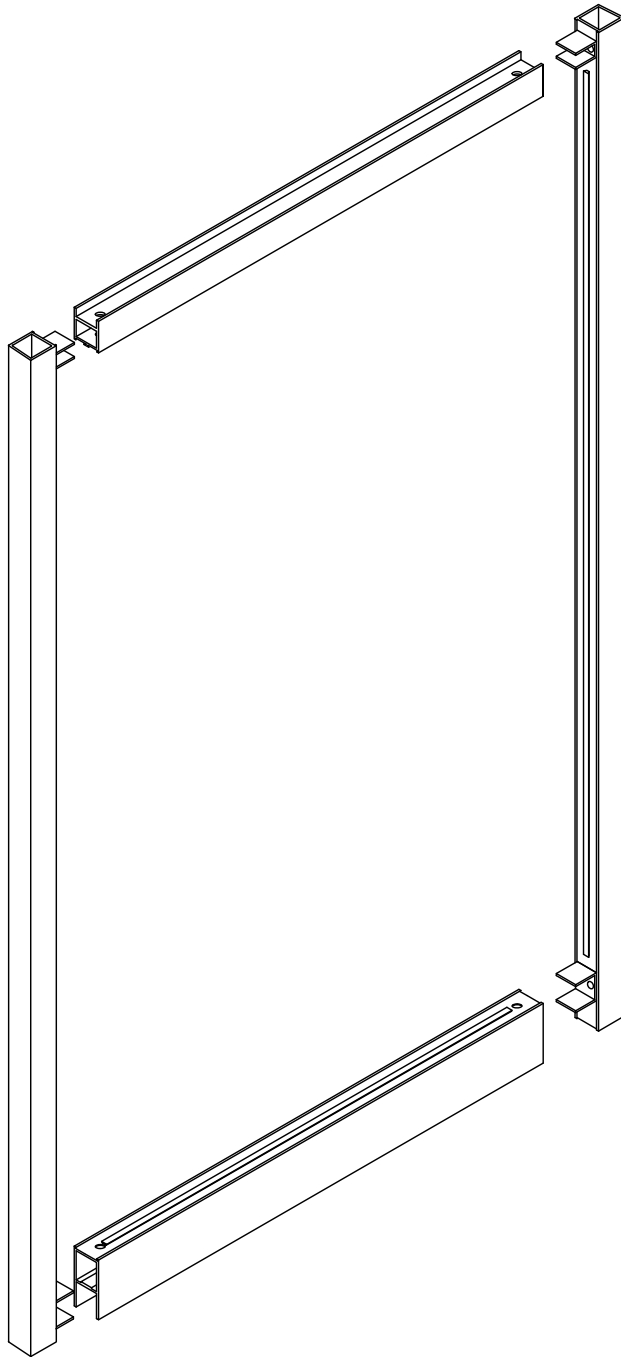

DOOR CONSTRUCTION DETAILS

A2

100 SERIES DOOR IS ILLUSTRATED
ALL DESA DOORS ARE SIMILAR



DUAL MOMENT CORNER
CONSTRUCTION ACHIEVED BY
ATTACHING A 3/16" (5 mm)
EXTRUDED CHANNEL CLIP AT
ENDS OF DOOR STILES WITH
1/4"-20 BOLTS AND 3/16" NUT
PLATES.

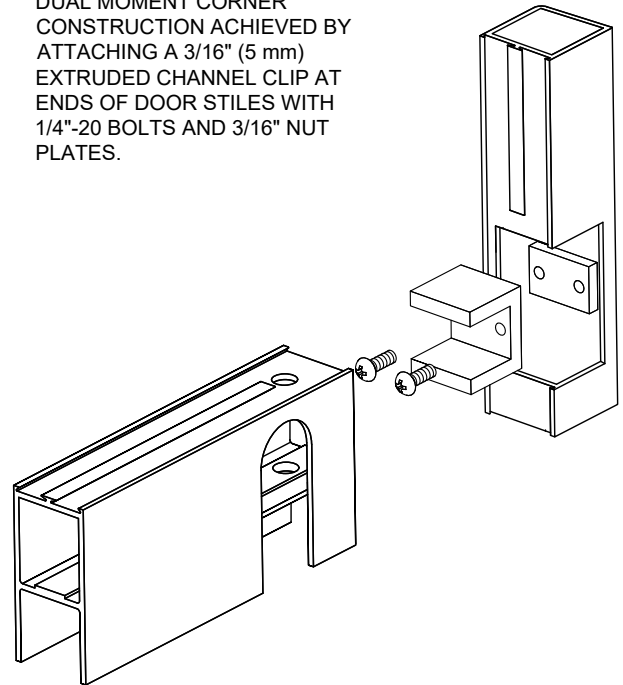

BOTH TOP AND BOTTOM RAILS
ARE ACCURATELY POSITIONED
OVER THE CHANNEL CLIPS
PRIOR TO APPLYING BOTH THE
FILLET WELDS AT THE TOP
AND BOTTOM RAIL WEBS AND
THE DEEP PENETRATION PLUG
WELDS TOP AND BOTTOM
PROVIDING AN EXTRA HIGH
STRENGTH CORNER JOINT.
(FOUR WELDS PER CORNER)

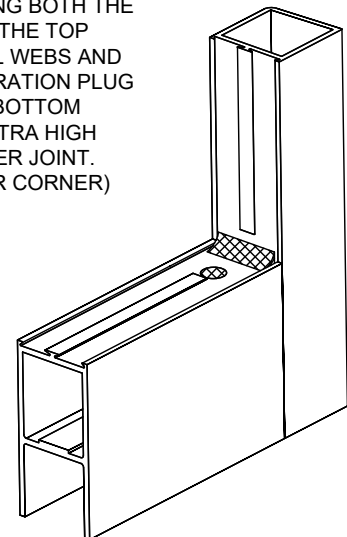

Clearly Exceptional

Providing innovative solutions that meet client needs | desa.ca