

90 SERIES WINDOW FRAMING DETAILS

D6

- 3 1/2" (88.9) THERMALLY IMPROVED FIXED WINDOW FRAMING SYSTEM FOR SEALED UNIT GLAZING.
- FRAMING SYSTEM CAN BE SPECIFIED FOR BOTH PUNCHED WINDOW AND HORIZONTAL STRIP WINDOW DESIGNS, WITH OR WITHOUT VERTICAL AND HORIZONTAL INTERMEDIATE MULLIONS.
- THE MAIN WINDOW FRAME SECTIONS ARE ROLLED TOGETHER WITH A CELLULAR FOAM P.V.C. AND OFFER THE OPTION OF COMBINING DIFFERENT EXTERIOR AND INTERIOR FINISHES TO THE FRAMING COMPONENTS. OPTIONS CAN INCLUDE USING STRONG EXTERIOR COLOURS COMBINED WITH MORE NEUTRAL INTERIOR TREATMENTS.
- THIS IS A PRIME SEAL WINDOW SYSTEM THAT EMPLOYS AN EXTERIOR PRE- SHIMMED GLAZING TAPE TO DETER AIR AND WATER INFILTRATION.
- SIMPLE SCREW SPLINE JOINERY WITH ALL FRAMING PARTS OFFERS ECONOMICAL FABRICATION AND INSTALLATION.
- SYSTEM ACCEPTS THE 20 SERIES VENT WINDOW INSERT FOR VENTILATING PURPOSES, IF REQUIRED.
- INTERIOR GLAZED SYSTEM PERMITTING EASY SEALED UNIT INSTALLATION AND REPLACEMENT FOR MULTI-STOREY BUILDINGS.

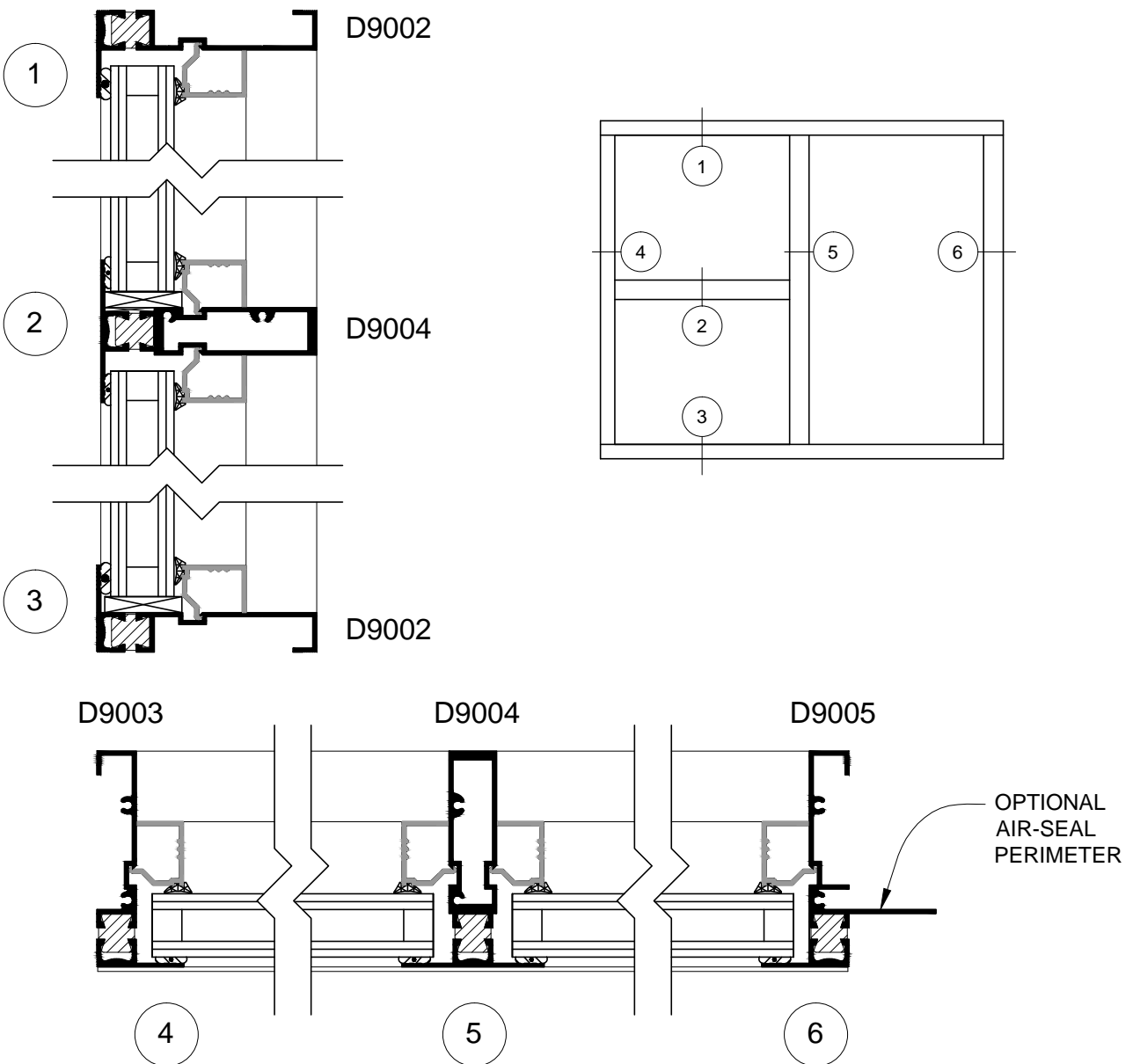

SCALE: 3/8" = 1"



providing innovative solutions that meet client needs.

90 SERIES WINDOW FRAMING DETAILS

D7

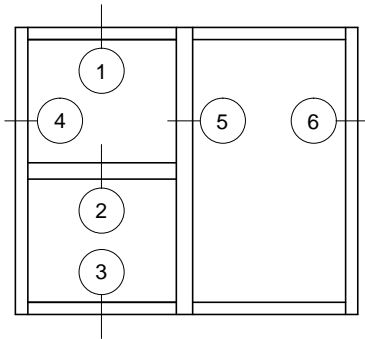

DETAILS USING 9006 - 9007 COUPLING MULLION

- WHEN USING THE COUPLING MULLION WITH 90 SERIES FRAMES, 9002 HEAD & SILL EXTRUSION AND 9003 JAMB EXTRUSION MUST BE INTERCHANGED TO ACCOMMODATE PROPER FABRICATION.

WIND LOAD CHART

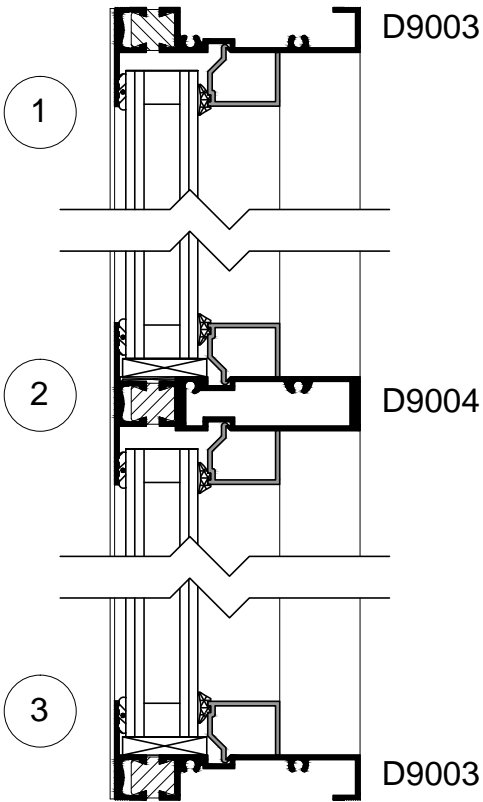
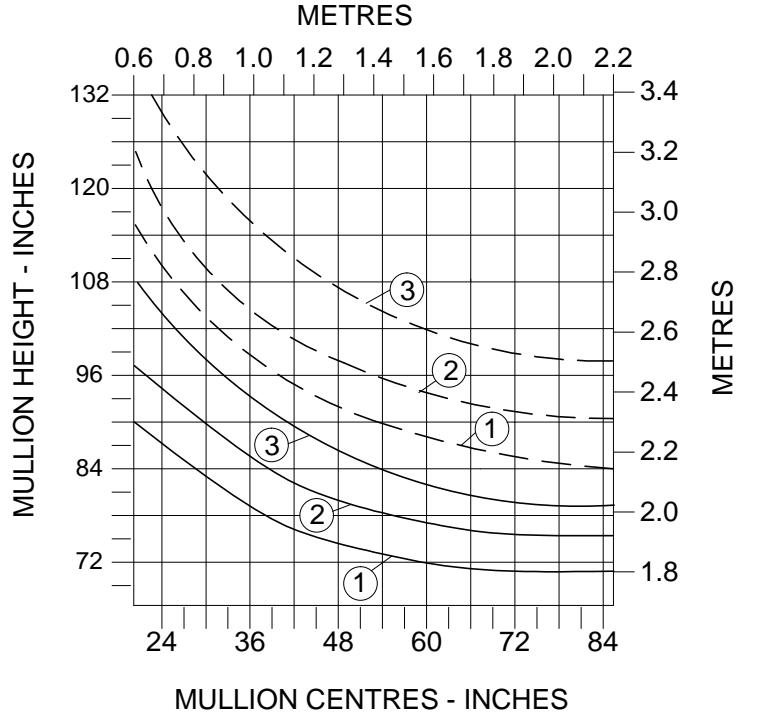

D9002

D9006 / D9007

D9005

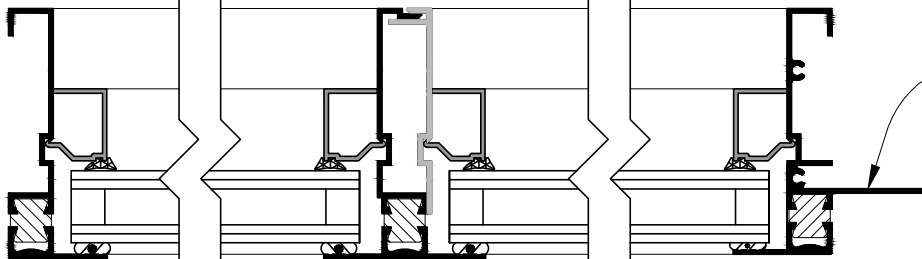

4

5

COUPLING
MULLION

6

SCALE: 3/8" = 1"



providing innovative solutions that meet client needs.

90 SERIES WINDOW FRAMING PARTS

D8

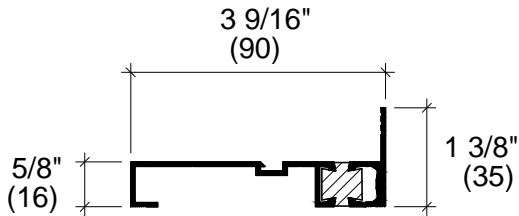

D9002
HEAD & SILL

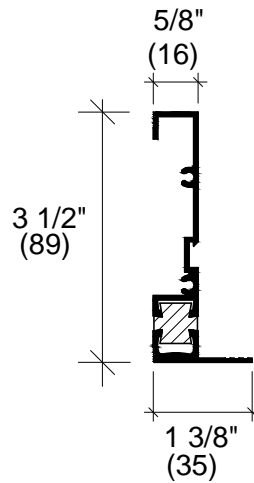

D9003
JAMB

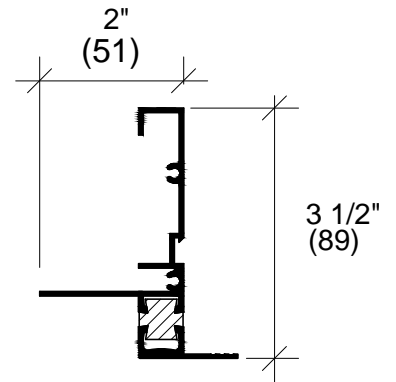

D9005
OPTIONAL AIR-SEAL
PERIMETER

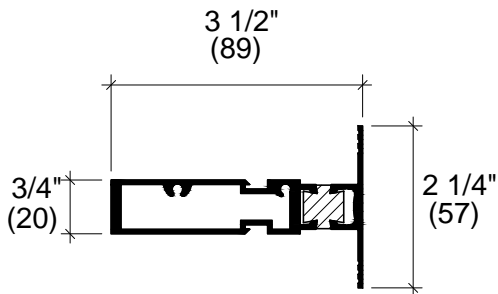

D9004
MULLION

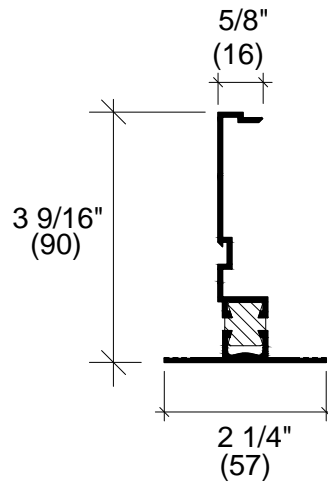

D9007
COUPLING MULLION
(FEMALE)

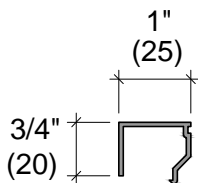

D9001
GLASS STOP

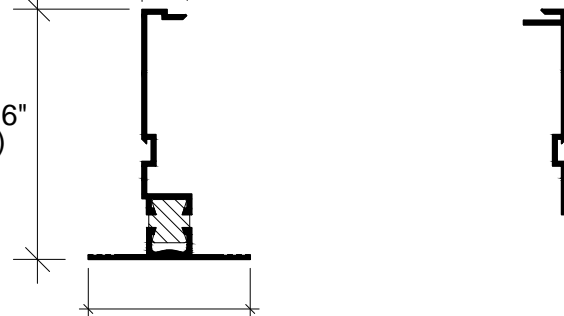

D9006
COUPLING MULLION
(MALE)



3/16" SHIM TAPE
FOR HEAD & SILL
9002



1/8" SHIM TAPE
FOR JAMB & MULLION
9003-9004-9005



N215
ROLL IN
GASKET FOR
1" UNITS

SCALE: 3/8" = 1"



providing innovative solutions that meet client needs.