

# 200 SERIES FLUSHLINE DETAILS

# B6

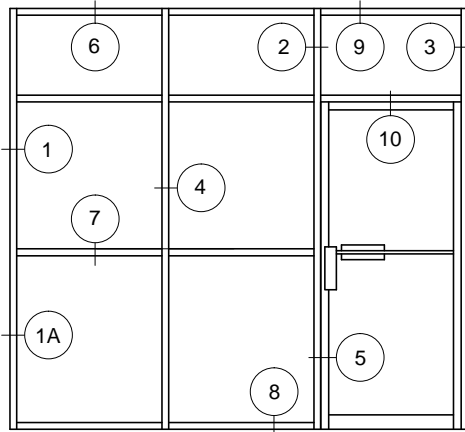

- THERMALLY IMPROVED 2" X 4 1/2" FLUSH GLAZED STOREFRONT AND ENTRANCE FRAMING SYSTEM FOR SEALED UNIT GLAZING.
- OFFERS A NARROW 2" SIGHT LINE AND IS TOTALLY COMPATIBLE WITH ALL DESA ENTRANCE DOOR PACKAGES, T/B AND NON T/B TYPE.
- THIS SYSTEM UTILIZES A TWO PIECE SPLIT MULLION DESIGN WITH SCREW SPLINE JOINERY FOR EASY FABRICATION.
- SHEAR BLOCK JOINERY IS REQUIRED AT THE TUBULAR DOOR JAMBS AND PROVIDES THE EXTRA STRENGTH REQUIRED AT THE ENTRANCEWAY.
- ENERGY EFFICIENT POUR AND DEBRIDGE THERMAL IMPROVEMENT DESIGN IS INCORPORATED IN ALL EXTRUDED SECTIONS.
- EXTRUDED THERMALLY IMPROVED SUB-SILL FLASHING HAS BEEN SPECIFICALLY DESIGNED AND IS RECOMMENDED FOR ALL WINDOW INSTALLATIONS.
- OPTIONAL TWO PART THERMALLY IMPROVED DEFLECTION HEADER PROVIDES EASY INSTALL OF FRAME, AND ALSO MEETS THE NEED TO PERMIT ANY DEFLECTION ABOVE THE OPENING.
- CLEAR AND BRONZE ANODIZED FINISHES ARE STANDARD. OTHER FINISHES ARE OPTIONAL.

OPTIONAL FILLER FOR  
CLOSED BACK JAMB

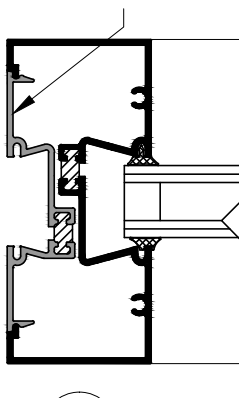

1

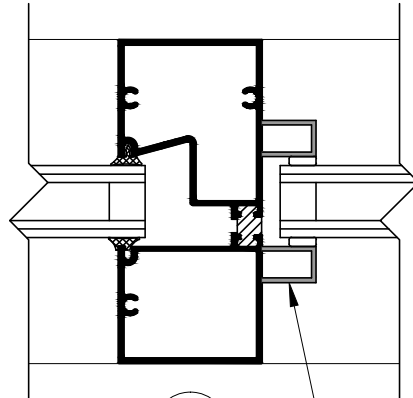

2

SCREW APPLIED  
VERTICAL STOPS  
ON TRANSOM

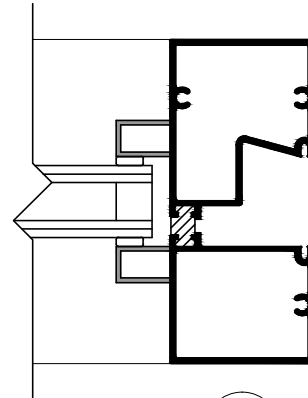

3

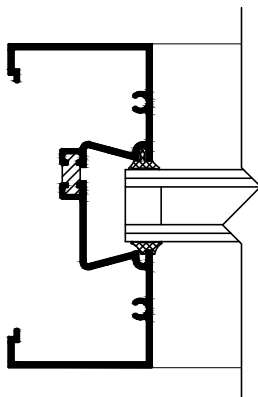

1A

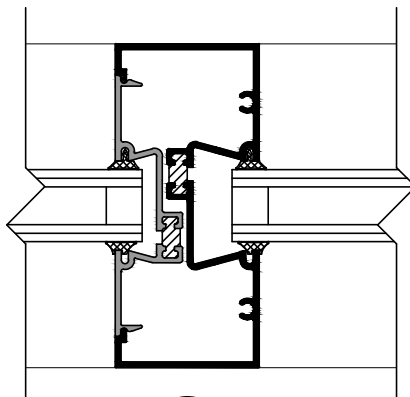

4

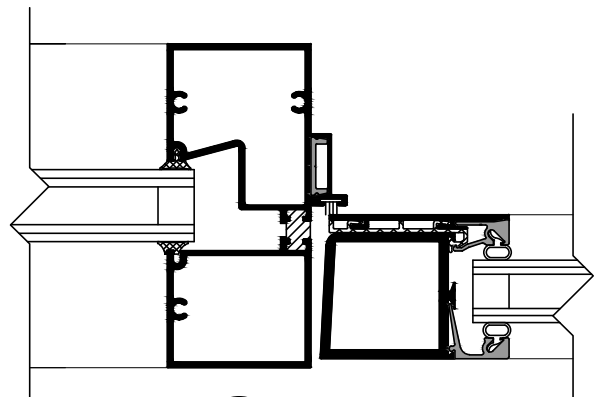

5

SCALE: 3/8" = 1"



providing innovative solutions that meet client needs.

# 200 SERIES FLUSHLINE DETAILS

# B7

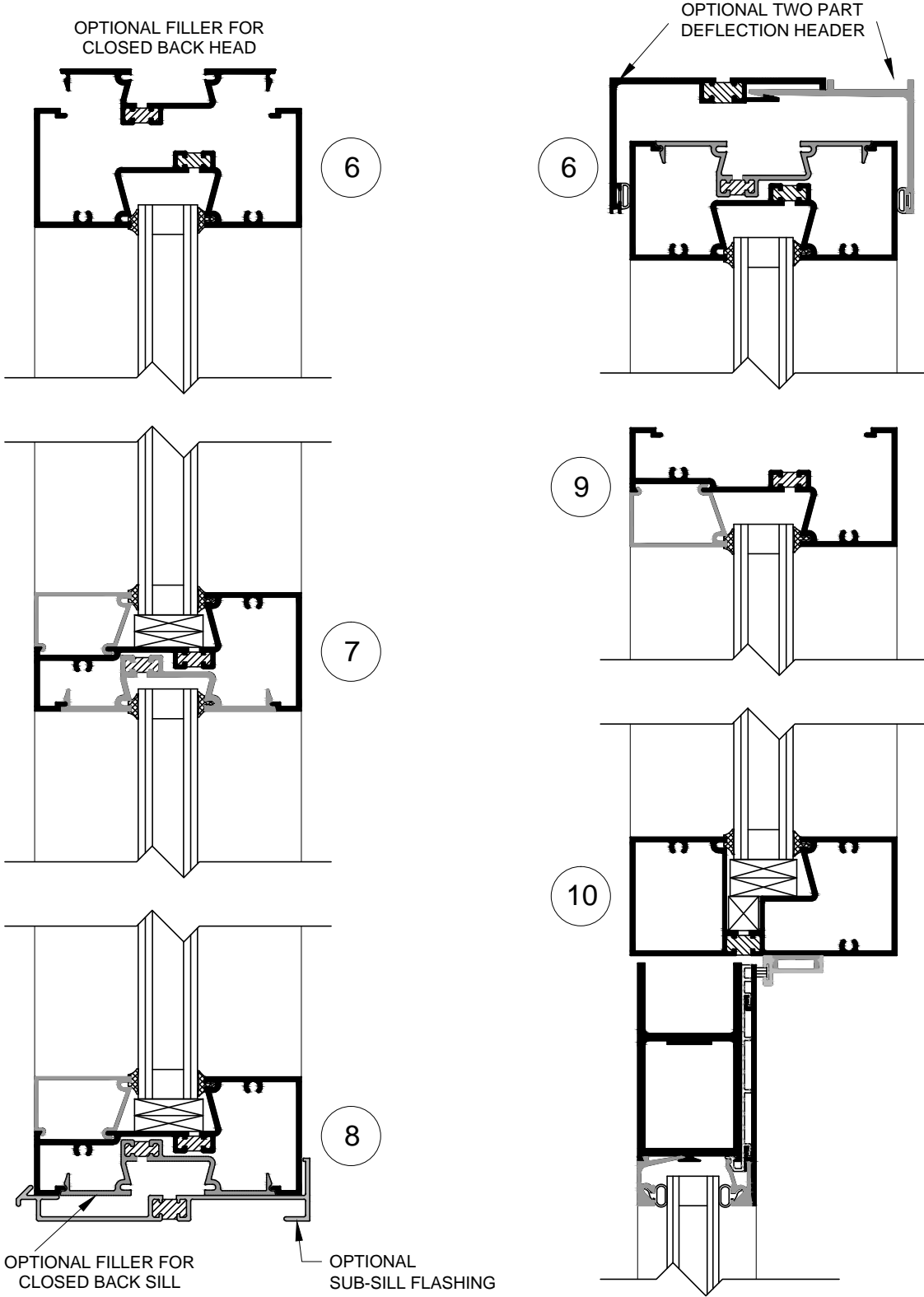

SCALE: 3/8" = 1"



providing innovative solutions that meet client needs.

# 200 SERIES FLUSHLINE FRAMING PARTS

# B8

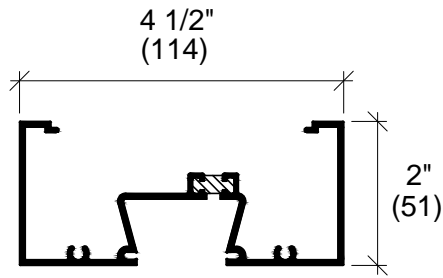

**F2001**  
OPEN BACK MULLION

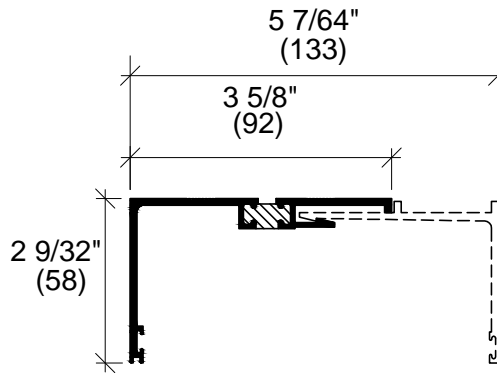

**D8007**  
DEFLECTION HEAD  
FEMALE

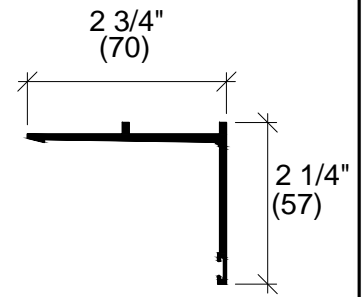

**F2007**  
DEFLECTION HEAD  
MALE

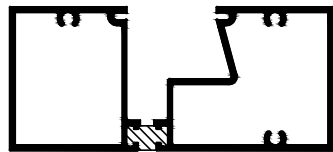

**F2002**  
DOOR MULLION / HEAD

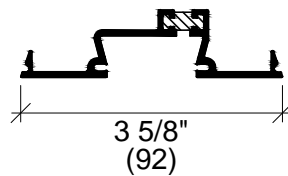

**F2004**  
MULLION / SILL FILLER

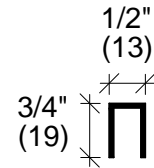

**D403**  
SCREW APPLIED STOP  
FOR TRANSOM



**F2005**  
SILL STOP

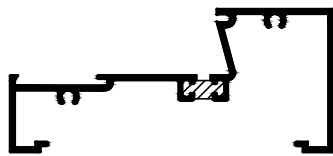

**F2003**  
OPEN BACK SILL

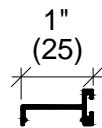

**F2008**  
DOOR STOP  
COVER



**N213**  
FIXED GASKET



**F2009**  
DOOR STOP  
BASE



**N215**  
FACE GASKET

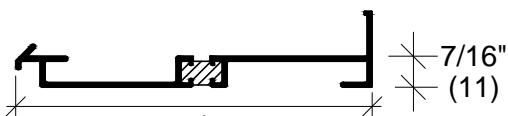

**F2006**  
SUB-SILL



**A14**  
SHEAR BLOCK



**B202**  
BULB GASKET FOR  
DEFLECTION HEADER

SCALE: 3/8" = 1"



providing innovative solutions that meet client needs.